

## OTP Speech Chip SC5040B

### 1、Description

The SC5040B are single-chip voice synthesizing CMOS IC. They are embedded EPROM architecture, and OTP (One Time Programmable) Speech chip, Each body has one input and two I/O pins. Through accurate internal oscillation, external R<sub>osc</sub> is unnecessary. There is PWM and 13bit DAC output for voice. Thus any external component is not required. Maximum 128 voice groups. serial mode maximum 255 voice groups ,mobile One Group contain several steps(voice section ); Maximum 1536 steps and 16 steps volume control for all the Groups. Maximum 44.1Khz Play Rate, Maximum 40 seconds Voice/ Midi. Each Step can be define Trigger Mode, Output Status, Voice Section, Mute length, I/O Type & Simple Programming Function. Support three mode trigger IC (Stand Alone, Serial Trigger Mode ). Easy use development system is for function selection and voice combination . PC download the ROM code by the OTP\_Writer.

### 2、Funtions :

(1).MAX voice file : 1536

- (2).MAX Trigger Groups : 255
- (3).MAX Step : 768
- (4).Operating Voltage range: 2.0V ~ 5.5V
- (5).Total Voice Duration : 40S (6K Samples)
- (6).I/O pin : 3
- (7).Voice output : PWM/DAC
- (8).Sequential Key : OKY1 -> 128 Groups. IO1-> 1 Group. IO1-> 1 Group
- (9).Debounce time : 1ms us or 100 ms
- (10)Step can change Trigger I/O Type, Trigger Mode & Output Status.
- (11).SOP8 Package。
- (12).Three Mode Trigger IC :
- (13).Key Stand-alone Trigger Mode :
  - A. Edge/Level
  - B. Hold/Unhold
  - C. Retrigger/Irretrigger
- (14).Serial Trigger Mode :  
Combinations of OKY to trigger maximum 127 Voice Group.
- (15).Output status (for each Output pin):

- A. Stand by Status. (High/Low Status)
- B. Busy Low Active.
- C. Busy High Active.
- D. LED Flash at 6 Hz.
- E. LED Flash at 3 Hz.
- F. LED Flash at 1.5 Hz.
- G. PWM for LED Dimming Control.

### 3、PAD Description:

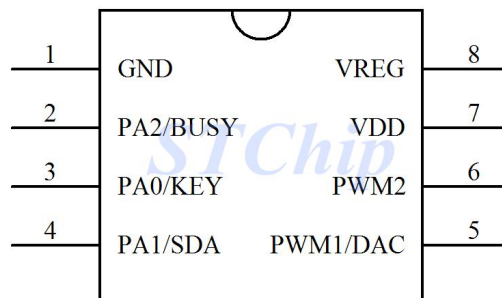

Pad No	Pad Name	Description
1	GND	Connected to Ground.
2	PA2/BUSY	Key Stand-alone Trigger Mode : is used trigger Only One Group. As Output PIN to Voice play busy
3	PA0/KEY	Key Stand-alone Trigger Mode : This used to trigger the maximum 128 Voice.
4	PA1/SDA	Serial Mode : is used to control maximum 255 Voice Group As Output PIN
5	PWM1/DAC	As a PWM or DAC PIN , can Directly drive the Speaker

6	PWM2	As a PWM PIN , can Directly drive the Speaker .
7	VDD	Power Supply PIN , Connected with a 0.1 uF to VSS.
8	VREG	Programming PIN

## 4、DC Electrical Characteristics:

### 4.1、Maximum Rating

Symbol	Rating	Unit
VDD~GND	-0.5 ~ +6.0	V
Top (operating)	-20 ~ +80	°C
Tst (storage)	-25 ~ +85	°C

### 4.2、DC Characteristics

Parameter	Symbol	Min	Typ.	Max.	Unit	Condition
VDD	VDD	2.0	3.0	5.5	V	
Standby current	I <sub>sb</sub>		1	5	uA	VDD=3V, no load
Operating current	I <sub>op</sub>		2		mA	VDD=3V, no load
			2.4		mA	VDD=4.5V, no load
Output drive current	I <sub>od</sub>		20		mA	VDD=3V
			40		mA	VDD=4.5V
Input current	I <sub>os</sub>		-10		mA	VDD=3V
			-20		mA	VDD=4.5V
PWM output current	I <sub>pwm</sub>		60	70	mA	VDD=3V, Load=8 Ω
			100	110	mA	VDD=4.5V, Load=8 Ω
DAC output current	I <sub>dac</sub>		0.36-4.20		mA	VDD=3V
			0.47-4.85		mA	VDD=4.5V

### 5、Play Rate:

1	2	3	4	5	6	7	8
32kHz	24 kHz	19.2 kHz	16 kHz	12 kHz	10.66kHz	9.6kHz	8.72 kHz
9	10	11	12	13	14	15	16
8kHz	7.38 kHz	6.85 kHz	6.4 kHz	6 kHz	5.64kHz	5.33kHz	5.05 kHz
17	18	19	20	21	22	23	24
4.8kHz	4.57kHz	4.36kHz	4.17kHz	4kHz	3.84kHz	3.69kHz	3.55kHz
25	26	27	28	29	30	31	32
3.42kHz	3.31kHz	3.2kHz	3kHz	-	-	-	-

### 6、Timing Diagram :

#### 6.1、Key Stand-alone Trigger Mode

Only one input pin can select Toggle On/Off function (1st

Trigg nput priority is OKY1 > IO1 > IO2

#### 1. Trigger Pulse Width < Group Length

Option Setting =Edge / Hold



#### 2. Trigger Pulse Width < Group Length

Option Setting = Edge / Unhold

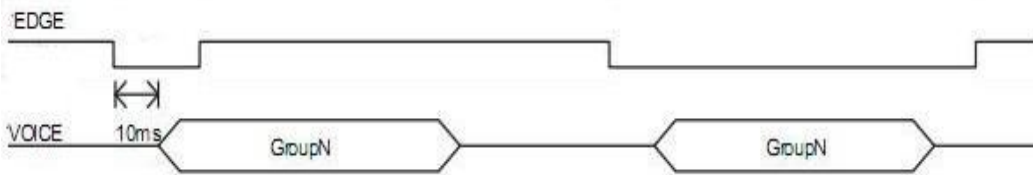

3. Option Setting = Retrigger

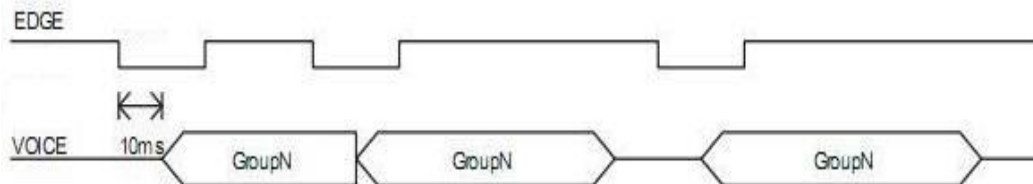

4. Option Setting = Irretrigger



5. Trigger Pulse Width < Group Length

Option Setting = Level / Hold

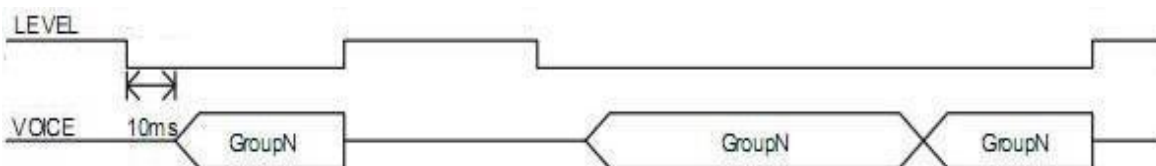

6. Trigger Pulse Width < Group Length

Option Setting = Level / Unhold

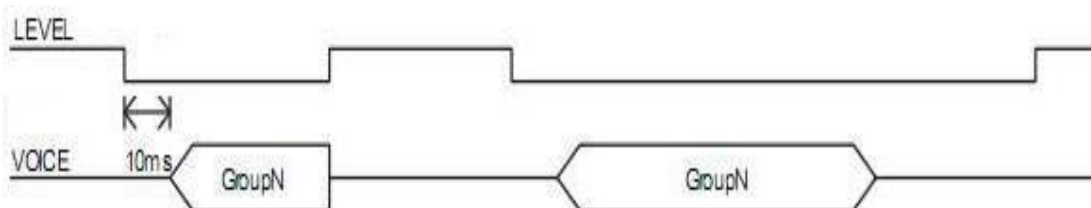

### 7. DATA= Sequential Trigger & From Group1~Group5

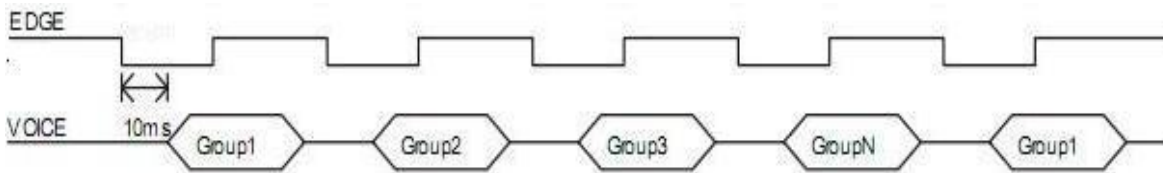

### 6.2、Serial Mode:

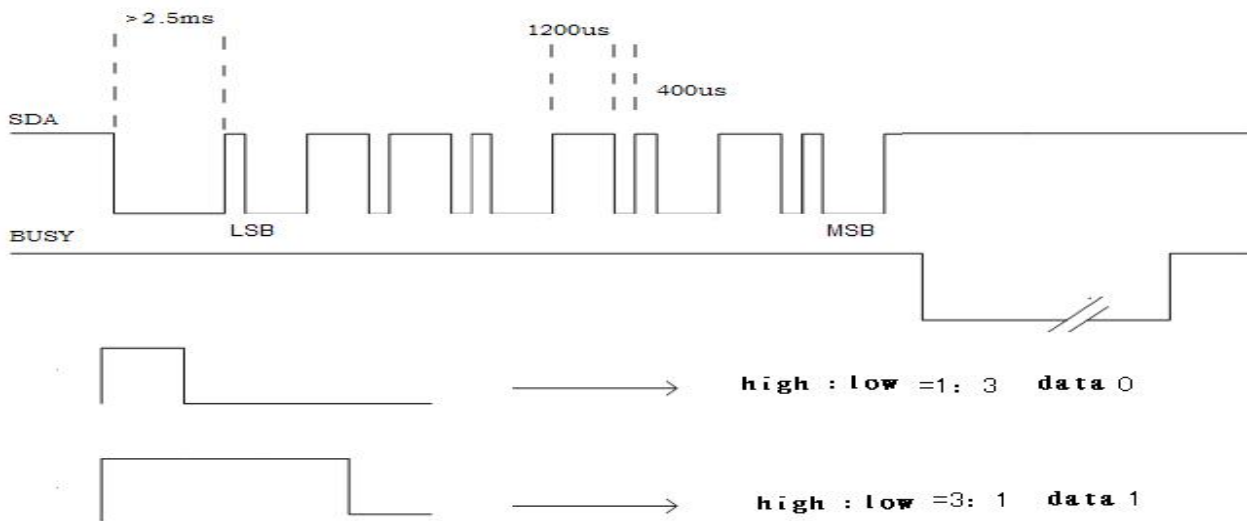

### 6.3、Command and Function:

Command	Function
01H	Voice 1 Group.
02H	Voice 2 Group.
XXH	Voice XX Group.
DFH	Voice 223 Group.
E0H~EFH	16 steps volume control , E0H Vol Min , EFH Vol Max
F2H	Loop Playback, XX Group+F2H
FCH	Audio on
FDH	Audio off
F3H	Exit the loop
FEH	Stop playing

## 6.4 Sample program:

```
void SC50X0_SDA(unsigned char data)
{
    unsigned char i;
    SDA = 0;
    delay_ms(5);
    for(i=0;i < 8;i++)
    {
        SDA = 1;
        if(data & 0x01)
        {
            delay_us(1500);
            SDA = 0;
            delay_us(500);
        }
        else
        {
            delay_us(500);
            SDA = 0;
            delay_us(1500);
        }
        data >>= 1;
    }
    SDA = 1;
    delay_us(200);
}
```



## 7、Application Circuit:

### 7.1、Stand-alone Mode(一)

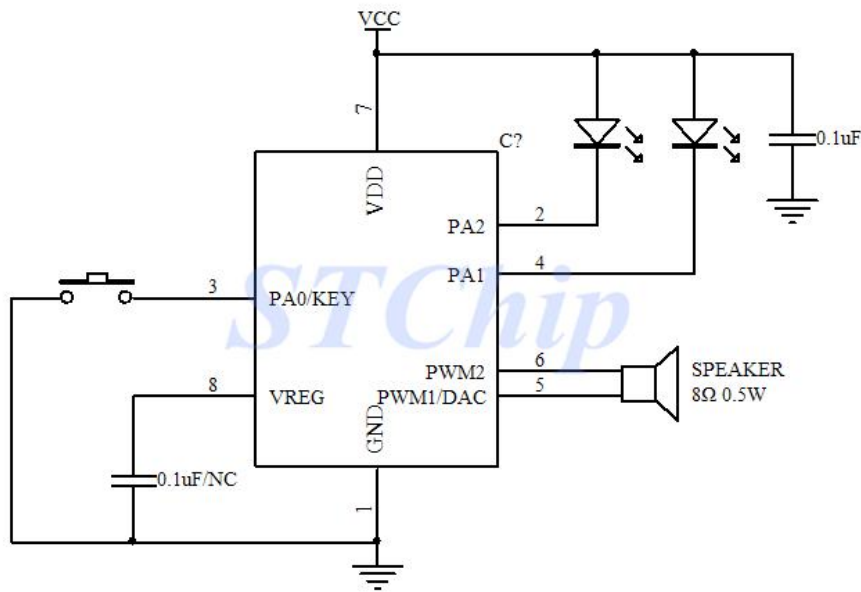

### 7.2、Stand-alone Mode(二)

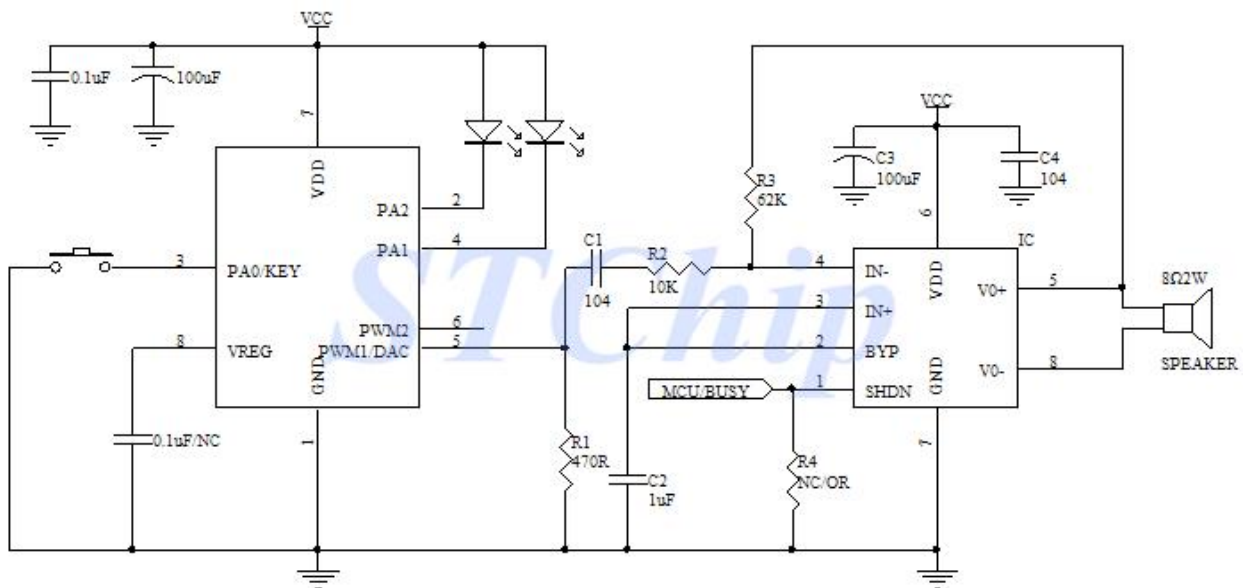

7.3、Serial PWM Mode

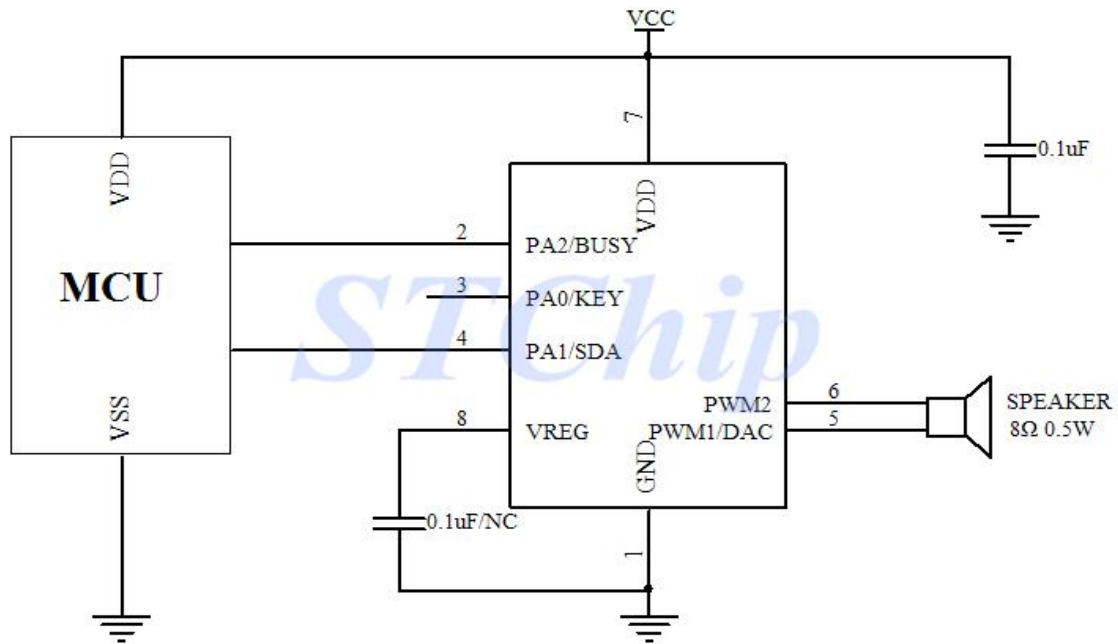

7.4、Serial DAC Mode

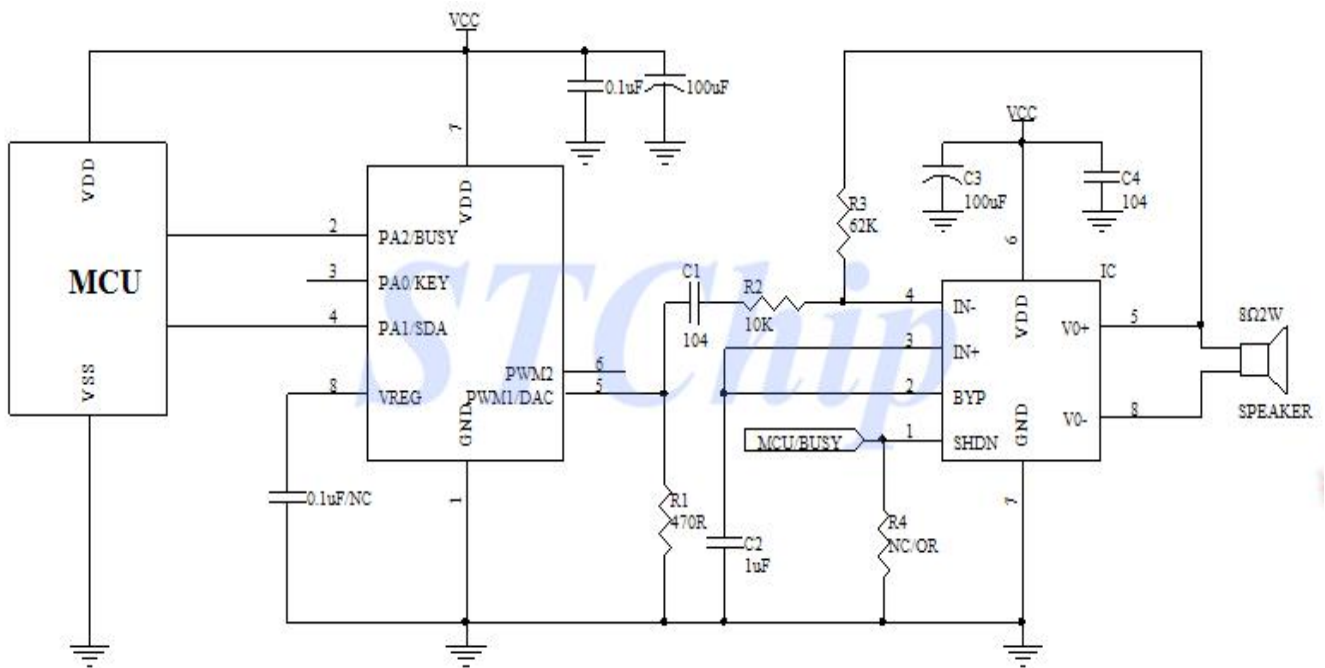

## 8、Package Information

### 1. SOP8 (150miL)

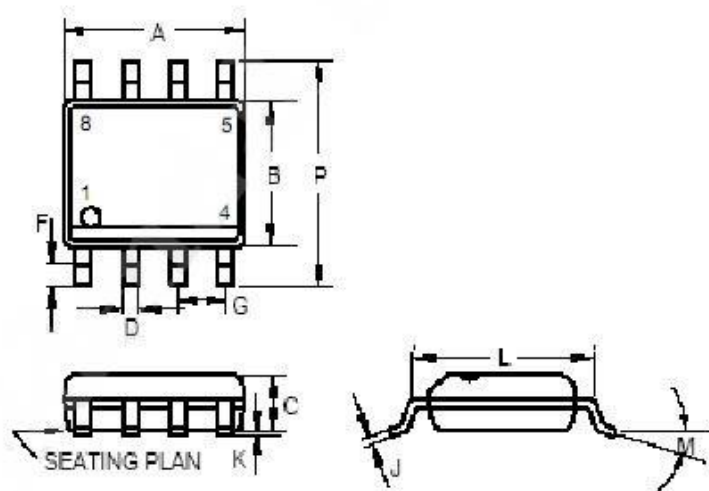

	INCHES			MILLIMETERS		
	MIN	TYP	MAX	MIN	TYP	MAX
A	0.183	-	0.202	4.65	-	5.13
B	0.144	-	0.163	3.66	-	4.14
C	0.068	-	0.074	1.35	-	1.88
D	0.010	-	0.020	0.25	-	0.51
F	0.015	-	0.035	0.38	-	0.89
G	0.050 BSC			1.27 BSC		
J	0.007	-	0.010	0.19	-	0.25
K	0.005	-	0.010	0.13	-	0.25
L	0.189	-	0.205	4.80	-	5.21
M	-	-	8°	-	-	8°
P	0.228	-	0.244	5.79	-	6.20