

Advanced Lithium Ion Linear Battery Charger

General Description

The SL1051 is a single Lithium-Ion or Lithium-Polymer cell linear battery charger which is designed for compact and cost-sensitive handheld devices. It combines charge status indication, charge termination, battery temperature monitoring, and high accuracy current and voltage regulation in a MSOP-8/SOP8 package.

The SL1051 charges the battery in three modes, precharge, constant current, constant voltage. If the battery voltage is below the precharge threshold $V_{O(MIN)}$, the SL1051 precharges the battery with a lower conditioning current. After precharge, the SL1051 applies a constant current to the battery. An external sense-resistor sets the charge current. The constant voltage mode continues until the battery reaches the regulation voltage.

The battery temperature is continuously measured by an external thermistor through the TS pin. The SL1051 inhibits charge until the temperature is within the range defined by users.

Features

For Single Lithium-Ion or Lithium-Polymer Cell Battery Pack (4.1V or 4.2V)

**A Few External Components are Required
Precharge, Constant Current, Constant Voltage Modes**

Battery Temperature Monitor

Charge Status Indication

Automatic Battery Recharge

Charge Termination Detect

Auto Low Power Sleep Mode when VDD Power is Removed

MSOP-8/SOP8 Package

RoHS Compliant and 100% Lead (Pb)-Free

Applications

Digital Cameras

PDA's

Cellular Phones

Information Appliance

Pin Configurations

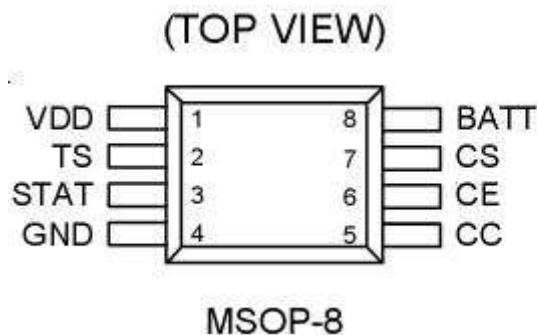

Functional Pin Description

Pin Name	Pin Function
VDD	Supply Voltage Input.
TS	Temperature Sense Input. Input from battery temperature monitoring circuit.
STAT	Charge Status Output. 3-state status indication of charge, charge complete and temperature fault or disable or sleep mode.
GND	Ground.
CC	Charge Control Output. Current output to drive on external PNP transistor or P-channel MOSFET for current and voltage regulation.
FB/CE	External Feedback Input or Charge Enable Function. Input from controller or finely adjust the battery regulated voltage with external voltage divider.
CS	Current Sense Input. Charge current is sensed according to the voltage drop from supply voltage to this pin.
BATT	Battery Voltage input. Input directly from battery voltage.

Function Block Diagram

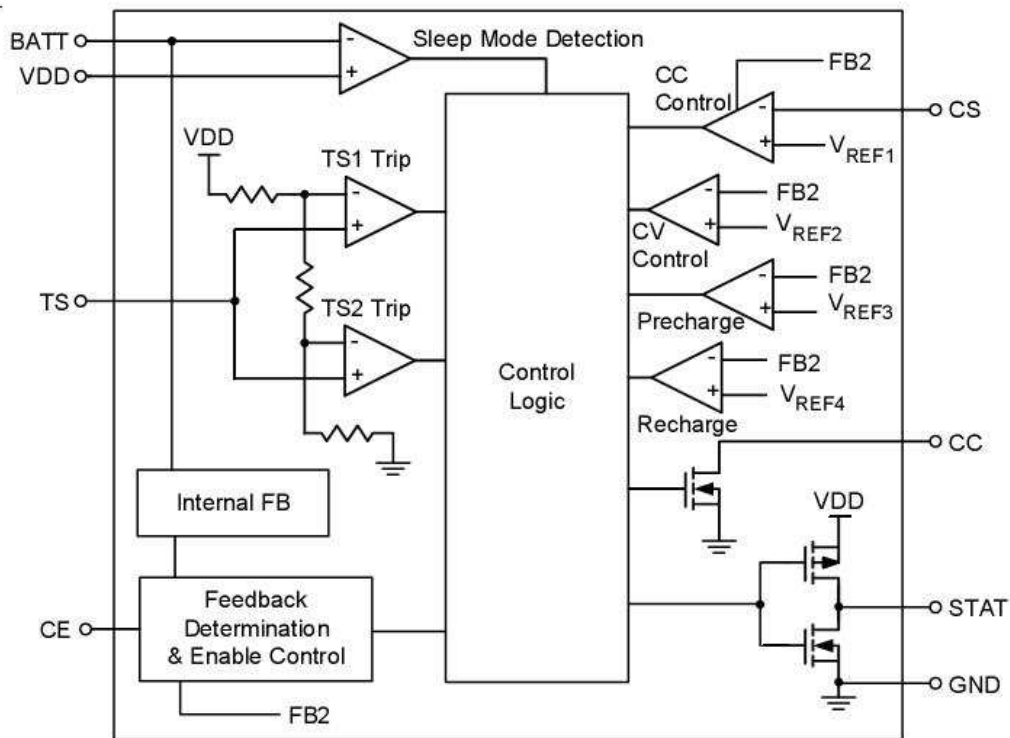

Absolute Maximum Ratings

□ Supply Voltage -----	-0.3V to 7V
□ Storage Temperature Range -----	-65° C to 150°C
□ Power Dissipation, P _D @ T _A = 25°C -----	300mW
□ Junction Temperature -----	150°C
□ Package Thermal Resistance	
□ Operation Junction Temperature Range -----	-40°C to 125°C
□ ESD HBM -----	2Kv

Electrical Characteristics

(T_A = 25°C, unless otherwise specification)

Parameter	Symbol	Test Condition	Min	Typ	Max	Units
Operating Current	IDD(OPE)	4.5V < VDD < 7V, Excluding external loads	--	1	2	mA
VDD Sleep Current	IDD(SLP)	VBATT - VDD ≥ 0.2V	--	--	3	μA
Input Bias Current @ BATT pin	IBATT	VBATT = VO(REG), VBATT - VDD ≥ 0.2V	--	1.5	2.5	μA
Input Bias Current @ CS pin	ICS	VCS = 5V, VBATT - VDD ≥ 0.2V	--	--	1	μA
Input Bias Current @ TS pin	ITS	VTS = 5V, VBATT - VDD ≥ 0.2V	--	--	1	μA
Input Bias Current @ FB/CE pin	ICE	VCE = 5V, VBATT - VDD ≥ 0.2V	--	--	1	μA
Input Low Voltage @ CE pin	VCE		--	--	1.5	V
Input High Voltage @ CE pin	VCE		VDD-1.2V	--	--	V
Output Voltage	VO(REG)		4.160	4.20	4.240	V
Current Regulation Threshold	VI(SNS)	VI(SNS) = VDD - VCS	95	110	125	V
Precharge Current Regulation	V(PRE)	V(PRE) = VDD - VCS	4	14	24	mV
Precharge Threshold	VO(MIN)		2.7	2.9	3.1	V
Recharge Threshold	VO(RCH)		VO(REG) - 170mV	VO(REG) - 110mV	VO(REG) - 50mV	V
Charge Terminated Current Detect Threshold	V(TERM)		2	12	22	mV
Output (Low) Voltage @ STAT pin	VSTAT(LOW)	IOL = 10mA	--	0.4	0.6	V
Output (High) Voltage @ STAT pin	VSTAT(HIGH)	IOH = 5mA	VDD-0.5	--	--	V
Lower Temperature Threshold	VTS1		29	31	33	%V DD
Upper Temperature Threshold	VTS2		57.5	59.5	61.5	%V DD

Typical Application Circuit

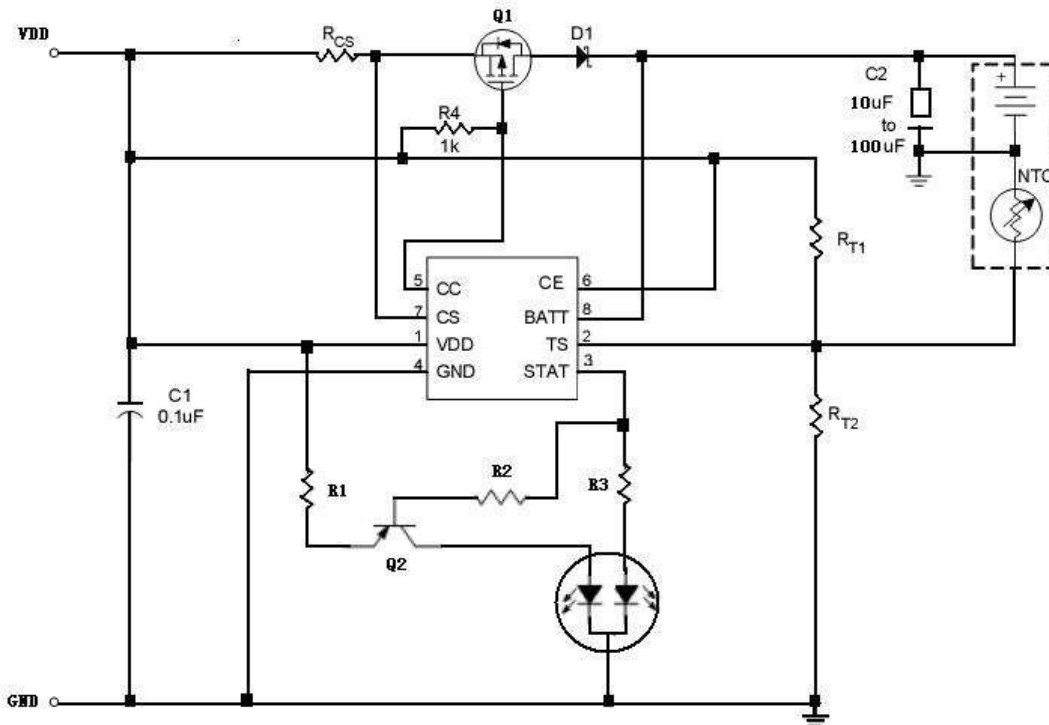
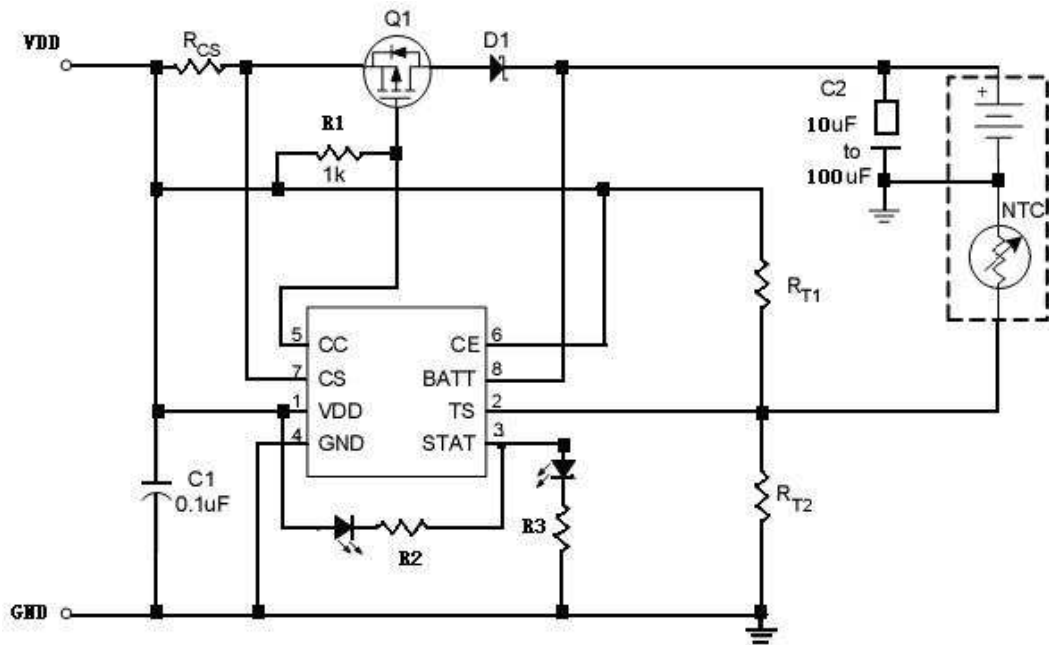

Figure 1. Application circuit using P-Channel MOSFET

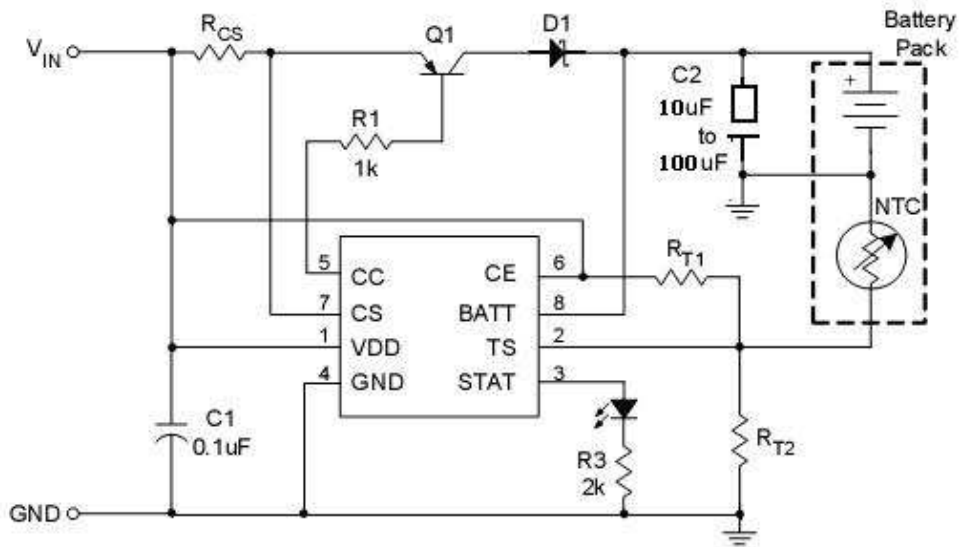

Figure 2. Application circuit using PNP transistor

Application Information

Charge Profile

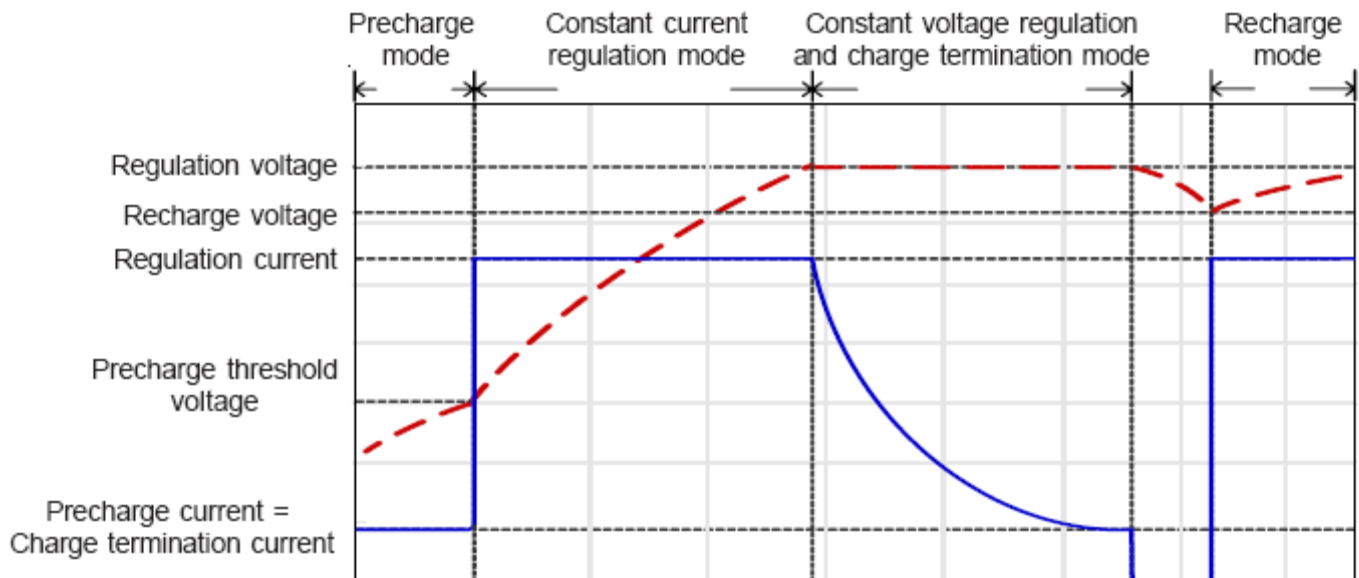

Figure 3. Typical charge profile

Detection

First, the FB/CE pin must connect to VDD or a voltage divider to enable the charge function. And then if a battery is already inserted and the input power source is absent, the SL1051 will enter sleep mode to prevent draining power from battery. When input power source and battery are both existed, another detection is the battery temperature. The TS pin voltage must be in the allowed range as shown in Figure 6 and the electrical characteristics, and then the SL1051 will start the charge cycle according to the battery voltage conditions.

Precharge Mode

When the battery voltage is lower than the precharge threshold $V_{O(MIN)}$, the SL1051 begins to charge the battery in precharge mode. In this condition, the precharge current is set at approximately 10% of the constant regulation current. The purposes of small precharge current are to minimize the power dissipation on the external switch during the precharge period and to revive deeply

discharged battery cells.

Constant Current Regulation Charge Mode

When the battery voltage is between the precharge threshold $V_{O(MIN)}$ and the regulation voltage $V_{O(REG)}$, the SL1051 starts the constant current regulation charge mode. SL1051 monitors charge current with voltage drop between two terminals of a sense-resistor, R_{CS} , which connects to pin VDD and CS. The following equation can calculate the desired charging current.

$$I_{O(REG)} = \frac{V_{I(SNS)}}{R_{CS}}$$

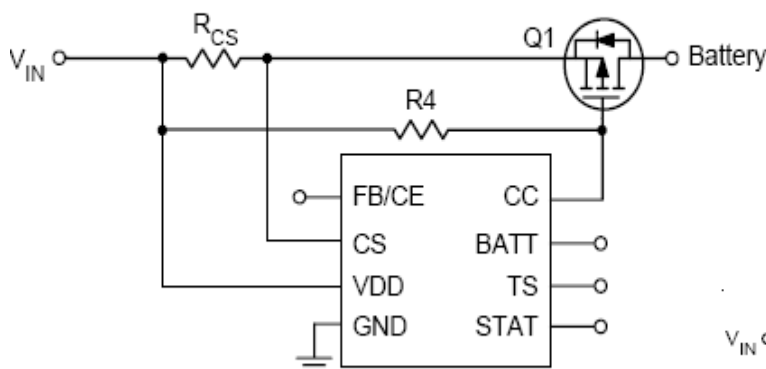

Figure 4

Constant Voltage Regulation and Charge Termination Mode

When the battery voltage reaches the regulation voltage $V_{O(REG)}$, the constant voltage feedback control starts, and then the charge current begins to decrease as the typical charge profile shown. As the charge current decreases to lower than charge terminated current threshold, the

SL1051 will terminate the charge cycle.

Recharge Mode

After the charge termination mode, if the battery voltage falls to lower than the recharge threshold voltage $V_{O(RCH)}$, the SL1051 will begin a new charge cycle according to the battery voltage.

Battery Temperature Detection

The SL1051 continuously detects the battery temperature by measuring the TS pin voltage. A NTC or PTC thermistor can parallel with R_{T2} to deviate the TS pin voltage. (As shown in Figure 5) The TS pin voltage must be within normal temperature voltage range that is shown in Figure 6 and electrical characteristics, and then SL1051 can start working normally.

The R_{T1} and R_{T2} can be derived from following equations.

For NTC Thermistors:

$$R_{T1} = \frac{5 \times R_{TH} \times R_{TL}}{3 \times (R_{TL} - R_{TH})}$$

$$R_{T2} = \frac{5 \times R_{TH} \times R_{TL}}{[(2 \times R_{TL}) - (7 \times R_{TH})]}$$

For PTC Thermistors:

$$R_{T1} = \frac{5 \times R_{TH} \times R_{TL}}{3(R_{TH} - R_{TL})}$$

$$R_{T2} = \frac{5 \times R_{TH} \times R_{TL}}{[(2 \times R_{TH}) - (7 \times R_{TL})]}$$

Where R_{TL} is the resistance value in lowest desired operation temperature and R_{TH} is the resistance value in highest desired operation temperature. The resistances of thermistors are specified by the thermistor manufacturer. If the temperature monitoring function is not desired, there's an easy method to set R_{T1} and R_{T2} at the same value and disconnect the thermistor to disable this function.

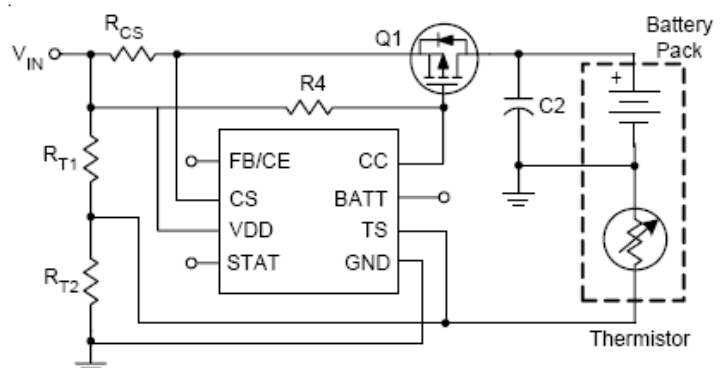

Figure 5

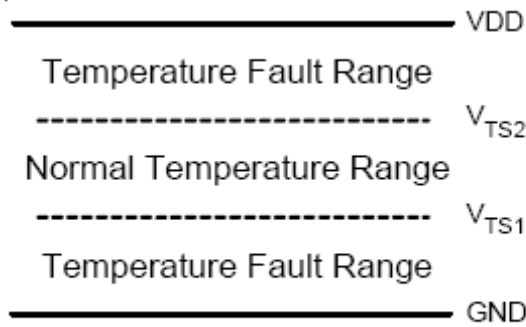

Figure 6

FB/CE Pin Functions

This pin has two functions, one is to enable/disable the charge function, and the other is to finely adjust battery regulation voltage. Connect this pin to VDD to enable SL1051, and connect to ground to disable it (Figure 7). If this pin is connected to a voltage divider as shown in Figure 8, it can be a 2.1V reference voltage to adjust the output regulation voltage as desired.

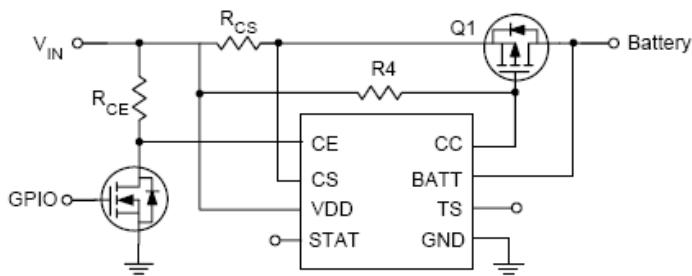

Figure 7. For CE pin Function

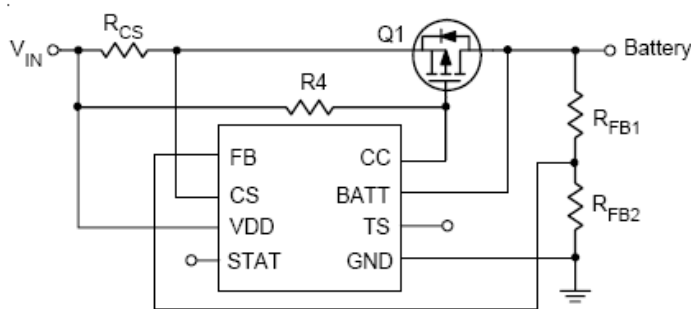

Figure 8. For FB pin Function

$$V_{O(REG)} = 2.1 \times \left(1 + \frac{R_{FB1}}{R_{FB2}}\right) V$$

Condition	STAT Pin
In battery charging cycle	High
Charge cycle completed	Low
Temperature fault or charge function disable or sleep mode	High Impedance

Selecting an External PNP Pass-Transistor or P-Channel MOSFET:

The SL1051 drives an external PNP transistor or PChannel MOSFET to control the charging current. The specifications must be concerned are the voltage and current rating and package power dissipation. The external switch is performed as a linear regulator. The maximum power loss occurs when the constant current regulation starts at the beginning, and it can be calculated approximately from following equation:

$I_{(SNS)}$ is the constant regulation current. The minimum voltage drop between the sense-resistor is 100mV, and the minimum precharge threshold voltage is 2.8V.

The external pass device with PCB heatsinking must be rated for the maximum power dissipation.

Selecting Input/Output Capacitor

In analog circuit applications, to place a high-frequency decoupling capacitor nearby the controller IC between input power source and ground is very important. A 0.1uF ceramic is recommended. If a high ripple and noise input power is chosen, it should have enough capacitance to reduce the disturbance.

A 10uF to 100uF output capacitor is recommended to control the output voltage and keep the output voltage ripple small when the battery is disconnected.

Outline Dimension

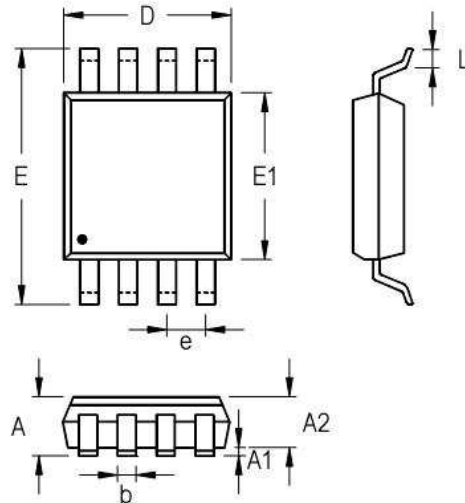

Symbol	Dimensions In Millimeters		Dimensions In Inches	
	Min	Max	Min	Max
A	0.810	1.100	0.032	0.043
A1	0.000	0.150	0.000	0.006
A2	0.750	0.950	0.030	0.037
b	0.220	0.380	0.009	0.015
D	2.900	3.100	0.114	0.122
e	0.650		0.026	
E	4.800	5.000	0.189	0.197
E1	2.900	3.100	0.114	0.122
L	0.400	0.800	0.016	0.031

8-Lead MSOP Plastic Package

SOP8 PACKAGE OUTLINE DIMENSIONS

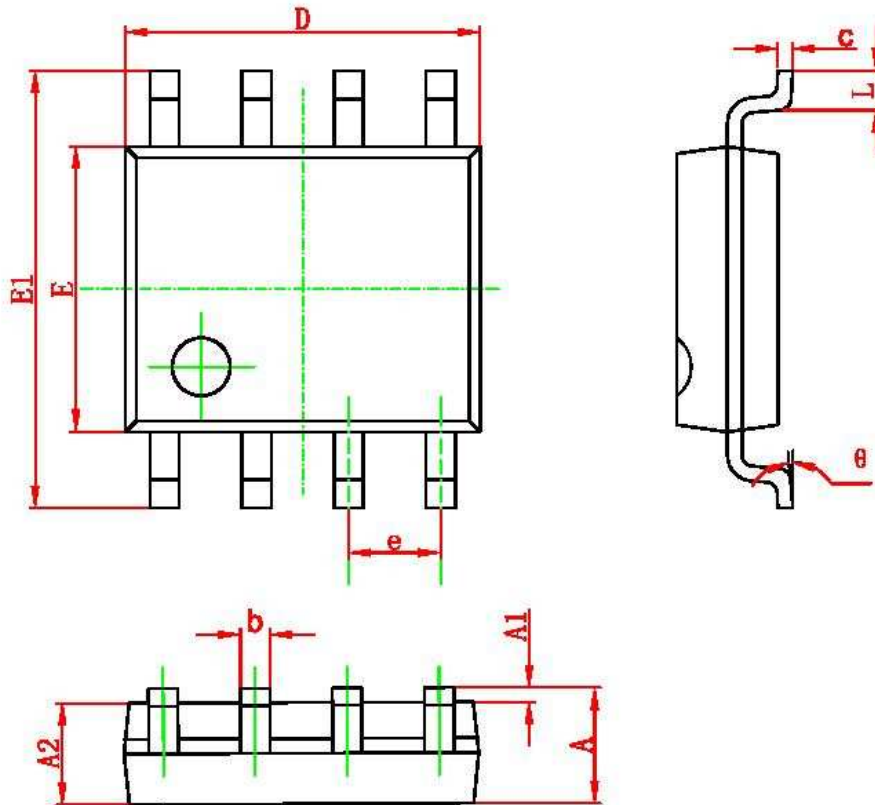

Symbol	Dimensions In Millimeters		Dimensions In Inches	
	Min	Max	Min	Max
A	1.350	1.750	0.053	0.069
A1	0.100	0.250	0.004	0.010
A2	1.350	1.550	0.053	0.061
b	0.330	0.510	0.013	0.020
c	0.170	0.250	0.006	0.010
D	4.700	5.100	0.185	0.200
E	3.800	4.000	0.150	0.157
E1	5.800	6.200	0.228	0.244
e	1.270 (BSC)		0.050 (BSC)	
L	0.400	1.270	0.016	0.050
θ	0°	8°	0°	8°